

CHAPTER 26 - 200CC SUPER

26.01 **Engine Eligibility:**

Must be series Production Engine
If Reed or Rotary - Must be Pre 1998 CIK Homologation.
All systems of 'Power Valve' forbidden.

26.02 **Engine Capacity:**

0 - 100cc by two OR 106cc - 141cc by one

26.03 **Carburettor:**

One single throat carburettor per engine.

26.04 **Ignition System:**

Only Group 2 CIK homologated ignition system/s are permitted.

26.05 **Tyres:**

1. No modifications permitted, Tyre Treatment is Illegal. (Refer Rule 23.03)
2. Dry Weather Tyres: Bridgestone YGK. (Two (2) sets / meeting)
Adjusted AKA Contracted Price: \$225.00 per set (max. retail fixed price)
Tyre bead retention applies. Refer Rule 23.02.
Wet Weather Tyres: any brand wet weather. (Two (2) sets / meeting)

26.06 **Braking:**

Front wheel brakes may be used. (Refer Rule 25.07).
Dual rear brake system is RECOMMENDED.

26.07 **Fuel:**

Refer Rule 25.14. Fuel, as run, to comply to test under Rule 22.01.

26.08 **Weights:**

106cc to 141cc - 125 Kg
141cc to 200cc - 180 Kg

26.09 **Limitations On Drivers:**

- (i) To be eligible to compete in this class, a competitor must hold an AKA A or B Grade licence.
- (ii) Drivers not having driven in this Class must complete a minimum of one (1) meeting displaying a 'P' Plate, to be removed through endorsement on the licence, on the satisfaction of the Stewards.
- (iii) Drivers entering this Class from Junior Classes who have not competed in Junior Piston Port must complete a minimum of three (3) meetings on 'P' Plates to be removed through an endorsement on the licence to the satisfaction of the Stewards.

CHAPTER 27 - 200CC CLUBMAN

27.01 **Engines:**

YAMAHA KT100S or ARC SPEC 100

27.02 **Tyres:**

1. No modifications permitted, tyre treatment is illegal (refer rule 23.03)
2. **Dry Weather Tyres** Bridgestone YGK (1 set + 1 replacement tyre / meeting)
Adjusted AKA Contracted Price: \$225.00 – Maximum Retail Fixed Price
Wet Weather Tyres Any brand from group 2 **CIK** (1 set + 1 replacement tyre / meeting) See chart chapter 23

27.03 **Braking:**

No front wheel braking system permissible.
Dual rear brake system is RECOMMENDED.

27.04 **Fuel:**

Refer Rule 25.14. Fuel, as run, to comply to test under Rule 22.01.

27.05 **Weight:**

170 kg

27.06 **Limitations On Drivers:**

To be eligible to compete in this class, a competitor must hold an AKA A or B Grade licence.

This Class to be run in accordance with Chapter 34 - 100cc CLUBMAN - with the following amendments.

27.07 **Exhaust Mufflers:**

Refer Rule 25.26 for technical specification.

- (i) Exhaust Mufflers and Header Pipes may be modified in the interest of safe fitting of dual exhaust systems. Average length must comply.

27.08 **Left Hand Motor:**

Left hand motor can have crankcase reversed without grinding, matching or machining of crankcases or cylinder. Genuine opposite rotation rotor can be used on Yamaha (Part Number 7F6-8551-50)

27.09 **Fin Dampeners:**

It is COMPULSORY that engines be fitted with a fin dampening system that effectively reduces noise. (Refer Clubman chapter).

CHAPTER 28 - INTERNATIONAL

28.01 **Preamble:**

As advised in the 1997 AKA Karting Manual this class has been combined with the Reed Class to become FORMULA 100 CLASS see Chapter 29. Classes based on FMK Regulations with equipment and components congruent to Formula 100 Class are detailed in Chapter 50.

CHAPTER 29 - FORMULA 100

Preamble

This class exists as an intermediate step for those senior karters wishing to compete in the FMK classes at national championships level and for karters being too heavy for the FMK weights. It is intended that the costs of competition in this class should be controlled however the technical requirements for engines will be the same as the FMK classes to allow easy exchange of equipment and easy transition through classes.

29.01 Engines:

- 1 Any homologated single cylinder series production air-cooled engine complying to FMK Formula A or Intercontinental A regulations is eligible
- 2 It must be possible to identify an homologated engine or its parts (cylinder head, cylinder, crank cases and crank shaft) by the technical descriptions (photos, technical drawings and the like) on the homologation forms.
- 3 Maximum capacity 101cc, except for pre 1998 engines which may be maximum 103cc.
- 4 All systems of powervalve are forbidden
- 5 In addition to any currently approved engines for the Formula 100 Class, newly homologated FMK engines will become eligible from 01 January in the year in which they are homologated by FMK and following registration with the AKA.
- 6 Unless otherwise specified all parts are to be by the original engine manufacturer.

29.02 Exhaust Port Timing:

The maximum exhaust port timing for Intercontinental A reed valve engines is 177 degrees, except for pre 1998 homologated engines. ****

29.03 Exhaust Port Height Check:

Stroke	Rod Length	Allowable Piston Travel
50.5	100	29.1
51.0	100	29.5
50.6	100	29.2
52.0	100	30.1
46.0	96	26.4
50.0	100	28.8
48.5	98	27.9

29.04 Modifications:

- 1 Modifications to homologated engines are permitted, **EXCEPT** to the following:
 - Stroke
 - Bore (outside maximum limits)
 - Number of transfer passages and inlet ports in the cylinder and crankcase.
 - Number of exhaust ports and passages.(the creation of new exhaust ports or passages is forbidden.)
 - Connecting Rod centreline.(magnetic material compulsory)
- 2 It must always be possible to identify the original parts of the homologated engine.

29.05 Ignition:

Only group 2 FMK homologated ignition system is permitted

29.06 **Non Tech Items:**

Unless otherwise specified, non tech items include – bearings and cages, crank pin, fasteners, gaskets, piston and rings, seals, piston pin, spacers, washers, spark plug. (refer Rule 25.25)

29.07 **Exhaust System:**

For reed valve engines (Intercontinental A) in this class it is not compulsory to use the FMK homologated exhaust pipe.

29.08 **Carburettor:**

1 Carburettor to be Formula A type :

A = 24.0mm OR A = 25.5mm

B = 27.8mm B = 25.5mm

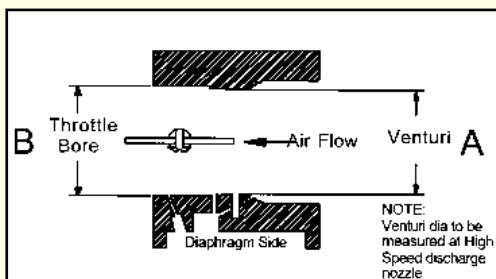

DIAGRAM IS FOR DIMENSIONAL REFERENCE ONLY

2 Carburettor may be either two or three jet - 25.4mm or 27mm.

3 All systems of injection and/or spraying of products other than fuel are forbidden.

29.09 **Fuel:**

Refer Rule 25.14. Fuel as run to comply to test under Rule 22.01.

29.10 **Tyres:**

1 No modifications permitted. Tyre Treatment is illegal. (refer rule 23.03)

2 **Dry weather tyres** Bridgestone YGK (1 set + one 1 replacement tyre / meeting)
Adjusted AKA Contracted Price: \$225.00 per set(maximum retail fixed price)

3 **Wet weather tyres** any tyre from group 2 CIK. (1 set + one 1 replacement tyre / meeting)
(see chart Chapter 23)

29.11 **Weight:**

1) formula 100 light - 140 Kg

2) formula 100 heavy - 160 Kg maximum kart weight 83 Kg
(kart as raced and prior to Class weight measuring)

29.12 **Limitations on Drivers:**

1) To be eligible to compete in this class, a competitor must hold an AKA A or B Grade licence.

2) Drivers entering this class from junior classes who have not competed in junior piston port must complete a minimum of three (3) meetings displaying P plates to be removed through an endorsement to the licence, on the satisfaction of the stewards.

CHAPTER 30 - PISTON PORT

Preamble

This section covers AKA approved Piston Port engines for Senior competition, Rules 30.01 to 30.18 Deleted 1997.

30.19 Engines:

- 1 Engines must be FMK approved for Intercontinental A Junior with AKA approval for direct drive crankshaft. The exception is for AKA homologated engines.
- 2 In addition to any currently approved engines for the Piston Port Class, newly homologated FMK engines will become eligible from 01 January in the year in which they are homologated by FMK and following registration with the AKA.
- 3 Unless otherwise specified all major parts are to be original engine manufacture.

30.20 Exhaust Port Height Check:

Mandatory Exhaust Port Height Check for 1770 maximum duration.

30.21 Exhaust Muffler:

Piston Port Engines are permitted to use the exhaust muffler homologated for use with that engine by the FMK or be the homologated muffler for a later model Piston Port engine from that engine manufacturer. If the homologated exhaust muffler is not used then the exhaust muffler used must comply with Rule 25.26.(a),(b),(c) and (e).

30.22 Tyres:

- 1 No modifications permitted. Tyre Treatment is illegal. (refer rule 23.03)
- 2 **Dry weather tyres** Maxxis HG3 (1 set + one 1 replacement tyre / meeting)
Adjusted AKA Contracted Price: \$208.00 per set (maximum retail fixed price)
- 3 **Wet weather tyres** any tyre from group 2 CIK. (1 set + one 1 replacement tyre / meeting)
(see chart Chapter 23)

30.23 Fuel:

Refer Rule 25.14. Fuel, as run, to comply to test under Rule 22.01.

30.24 Weight:

140 Kg

30.25 External Modifications:

External modifications which do not in any way affect a performance gain are legal.

30.26 Internal Additions:

- (i) No additional material may be added except in the case of engine repairs and shall only restore engine or components to original specifications.
- (ii) The use of thermal barrier coatings / ceramic coatings on or in exhaust components is prohibited.

30.27 Interchange of Parts:

Legal between engines of like dimensions (bore, stroke) as long as no removal or addition of material is required to interchange said parts.

30.28 Legal Additions:

Legal additions shall be limited to the following : Carburettor return springs, chain guard, direct drive sprocket, extension of carburettor jet needles, exhaust header, motor mount, muffler, starter nut and pulley, tachometer, temperature gauge, third bearing and adaptor shaft.

30.29 Limitations on Drivers:

To be eligible to compete in this class, a competitor must hold an AKA A or B Grade licence.

30.30 Non-Tech. Items:

Unless otherwise specified, non-tech. items include bearings and cages, crankpin, fasteners, gaskets, piston and rings, seals, piston pin, spacers, washers and spark plug. (Refer Rule 25.25).

30.31 Displacement:

The maximum bore including 5% tolerance.

30.32 Exhaust, Intake and Transfer Ports:

Modifications are permitted, except:

- (i) Number of transfer passages and inlet ports in the cylinder and crankcase.
- (ii) Number of exhaust ports and passages.
- (iii) Port surface finish is a non-tech item.

30.33 Deleted 2001

30.34 Connecting Rod:

Must be the same length as original and made of magnetic material.

30.35 Crankshaft:

Must be by original engine Manufacturer with no change of stroke permitted.

30.36 Ignition:

The only permissible ignition system is either of the following :

Group 2 FMK homologated or Yamaha.

1. The fitting of the module YAMAHA, VICTA, ATOM or DELTA/WEI SHIEH is permissible.

30.37 Carburettor:

Any butterfly type carburettor providing it comes within the following specifications:

- (i) Maximum two adjustable jets permitted
- (ii) No fixed jets permitted.
- (iii) All fuel to the engine must pass through the high and low speed fuel metering jets and passages.

Maximum size combination as follows:

1	A = 25.5mm	B = 25.5mm
2	A = 24.0mm	B = 27.8mm

For Walbro WB Carburettor

3	A = 25.4mm	B = 25.7mm
4	A = 24.0mm	B = 27.8mm

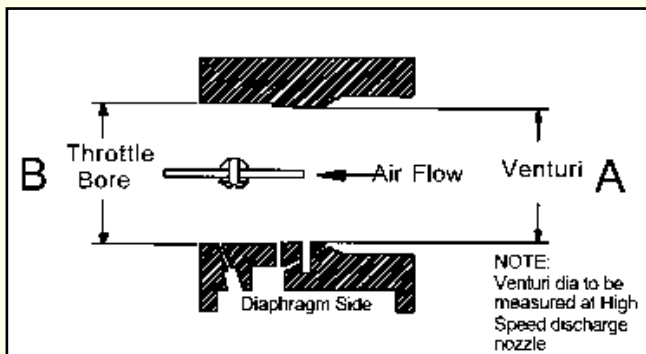

DIAGRAM IS FOR DIMENSIONAL PURPOSES ONLY

Chart

Engine	Bore (max)	Stroke.	Conrod Length	Piston Travel	Homologated Exhaust No.
ARC PP 50 A7 or W7	51.00	50.54	100		ARC PP52
ARC PP 52 A7 or W7	53.00	46.10	100		ARC PP52
ATOMIC AKP 92.	51.50	50.46	100	29.1	141E/92/ATO
CMP 92/142		46.00	96	26.4	
COMER MIK P50		51.50	100	29.1	
COMER MIK P52		52.00	100	30.1	
CRG S30-TI		50.50	100	29.1	
DAP T50	52.50	48.50			125E/92/DAP
DAP T51	53.90	46.00	100	26.2	125E/92/DAP
DINO M3		50.00	100	28.8	
DINO 500PP	51.70	50.00			
DINO 502 PP		50.00	100	28.8	110E/92/DIN
FOX MC30P		50.60	100	29.2	
ITAL SISTEM MA1	52.45	48.50	98	27.9	132E/92/ITA
ITALSISTEM MA21	51.45	50.50	100	29.1	260E/95/ITA
KOMET K71	53.85	46.00	96	26.4	129E - 130E/92/IAME
ROTAX R100PP92	51.45	50.50	100	29.1	501M/89149/150M/92/ROT
PARILLA PV92,	51.70	50.00	100	28.8	129 - 130E/92/IAME
PARILLA PV95	51.70	50.00	100	28.8	245E/95/IAME
PCR PV95	51.45	50.50	98	29.2	280E/95/PCR
PCR PV50	51.70	50.00			
PCR PV100	51.70	49.95	100	28.8	145E/92/PCR
PRD RK100	51.70	50.00			9037/95A/PRD
SOLO PP98	51.70	50.00	100	28.8	225E/95/DAR
TITAN PP95		50.50	100	29.1	
TKM B 95		50.50	100	29.1	
VORTEX VA95	51.45	50.50	100	29.1	288E/95/VOR
YAMAHA KT100S	53.85	46.10	100	26.2	

All measurements are in mm

CHAPTER 31 – FORMULA AUSTRALIA

Any alterations / modifications are strictly prohibited except as specifically authorised within these rules

31.01 **Engines:**

- (a) ARC SPEC 100A
- (b) ARC SPEC 100W
- (c) ARC SPEC 100W / YAMAHA KT100S Hybrid–Watercooled

These engines are based on a Yamaha KT100S bottom end and a watercooled ARC SPEC 100W barrel and head.

31.02 **Chassis:**

- 1 For 2001, 2002, 2003 the chassis make / model is open
From 1 January 2004 must be Australian Made
- 2 Criteria for recognition / homologation as Australian Made available from the AKA National Office.

31.03 **Weights:**

- (a) Formula Aust Light 135 Kg
 - (b) Formula Aust Heavy – 155 Kg
 - (c) Formula Australia Super Heavy – 175 Kg
- (Maximum kart weight for Heavy and Super Heavy – 83 kgs)
(Kart as raced and prior to Class weight measuring). (Refer Rule 25.23 (b)).

31.04 **Driver Limitations:**

Minimum level is C Grade AKA licence

31.05 **Tyres:**

1 No modifications permitted, and Tyre Treatment is illegal. (Refer Rule 23.03)

2 **Dry Tyres:**

Maxxis HG3 1 set plus 1 replacement tyre / meeting. (Refer R 19.34.)
Adjusted AKA Contracted Price: \$208.00 per set. Maximum Retail Fixed Price

3 **Wet Weather Tyres:**

MAXXIS WT3TKM 1 set plus 1 replacement tyre / meeting. Refer R 19.34
Adjusted AKA Contracted Price: \$192.00 per set. Maximum Retail Fixed Price.

31.06 **Braking:**

Front wheel brakes are not permitted. Refer Rule 25.07 (i)

31.07 **Fuel:**

Refer Rule 25.14. Fuel, as run, to comply to test under Rule 22.01

31.08 **Pressurised Fuel System:**

Fuel pump or pressurised fuel systems are forbidden. Squeeze type pump between fuel tank and carburettor is permitted.

31.09 Carburettor:

Must be Walbro WB series conforming to dimensions as per diagram.
(Note - WB 24 is not acceptable)

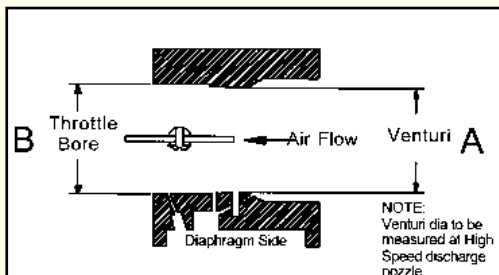

- (a) It is permissible to machine the Walbro carburettor body to
 - (i) conform to dimension E
 - (ii) conform to dimension C
 - (iii) accept an O ring for the low speed jet.
- (b) A threaded butterfly screw must be retained.
- (c) Pump diaphragms: Either Teflon or rubber types are legal.
- (d) It is permissible to repair the inlet seat and throttle shaft in the Walbro carburettor.
- (e) It is permissible to enlarge only existing fuel / air holes, but they may not be deleted or relocated.
- (f) All air must pass through the carburettor venturi.
- (g) Measurement code:
 - A As cast MAX Venturi diameter 24.13mm
 - B As cast (area will extend from the front of the carburettor to the progression discharge jet which must have all or portion of this jet in the cast area.)
 - C MAX downstream diameter 25.7mm
 - D Butterfly shaft must be located at the bore centre.
 - E MIN carburettor body length of 37.5mm.

31.10 Inlet Tract Length:

69mm min. (measured from aluminium carburettor adaptor outer face to skirt of piston)

31.11 Insulating Spacer:

Hole size 26.42mm max.

31.12 Aluminium Carburettor Mount Plate:

Hole size 26.29mm max

31.13 Exhaust Pipe Header:

This item is not restricted to the original Manufacturer but must completely conform to the type (style) and dimensional sizes of the original header pipe. Inside diameter must be parallel. Length must be a minimum of 120mm (as per new measuring method). Maximum inside diameter 36mm. Minimum diameter 34mm. Refer diagram. Modifications to fit exhaust gas temperature gauge sensors are permissible.

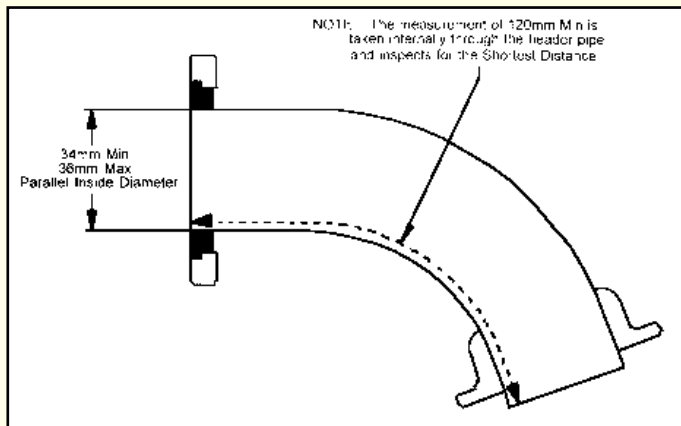

DIAGRAM IS FOR DIMENSIONAL REFERENCE ONLY

31.14 Exhaust Muffler:

A registered AKA silencer is mandatory for Formula Aust as of 1st July 2000. See rule 25.26

31.15 Ignition:

- Ignition must be that supplied by the original engine manufacturer which is approved by the AKA. Any optional unit must be approved and registered with the AKA for this class. The use of the following AKA approved TCI module is permissible:
YAMAHA, VICTA, ATOM, DELTA/WEI SHIEH, PRD
No modifications or repairs to any of the listed AKA approved modules is permitted. The fitting of a PRD ignition coil and a PRD ignition rotor (flywheel) is permissible.
- Ignition timing may be adjusted by the removal of the locating key or part thereof and/or by the ignition plate.
- All engines must rotate in a clockwise direction when viewed from the drive side.

31.16 External Modifications:

External modifications which do not in any way affect a performance gain are legal.

31.17 External Identification

The ARC Spec 100 water cooled must have "Mod 2" cast into the rectangular boss on the cylinder barrel above the drive side of the engine.

31.18 Internal Additions:

No additional material may be added except in the case of engine repairs and shall only restore engine or components to original specifications. The cylinder may NOT be repaired in any of the port or passage as cast or machined areas.

- (a) The use of thermal barrier coatings / ceramic coatings on or in the engine / engine components and on or in exhaust components is prohibited.
- (b) The use of anti friction coatings on or in the engine/engine components is prohibited.

31.19 Legal Additions:

Legal additions shall be limited to the following: Chain guard, motor mount, direct drive gear, extension of carburettor jet needles, carburettor return springs, third bearing and adaptor, temperature gauge and tachometer.

31.20 Clutch:

A clutch is not permitted in this Class.

31.21 Waterpump

Drive, type and mounting is optional.

31.22 Non-Tech Items:

Refer Rule 25.25

31.23 Cylinder Head:

- 1 Must be an original ARC casting.
- 2 The welding and re-machining of the combustion area, gasket face and spark plug surface is allowable.
- 3 The combustion chamber style is required to have a squish band and chamber which are visually concentric to the spark plug.
- 4 The combustion chamber volume shall be a minimum of 11cc. (Ref rule 22.03)
- 5 The combustion chamber/squish area shall not protrude beyond the gasket sealing face of the cylinder head.
- 6 The spark plug thread may be repaired and shall retain its original position.

31.24 Displacement:

The maximum bore and stroke are:

Bore 53.00mm Stroke 46.13mm

31.25 Head Gasket/s:

Must be retained.

31.26 Piston:

1. Piston must be AKA approved ARC (forged or cast) and stock in appearance.
2. Approved aftermarket pistons for 2000 include YAMAHA, KSI, KSI MK II, JDP/Vertex and Strike.
3. Bottom of piston should be 90 degrees to sides. It is permissible to notch the piston to allow the removal of circlip. The piston skirt length may be machined, providing it conforms to the current specifications as laid down in these rules.

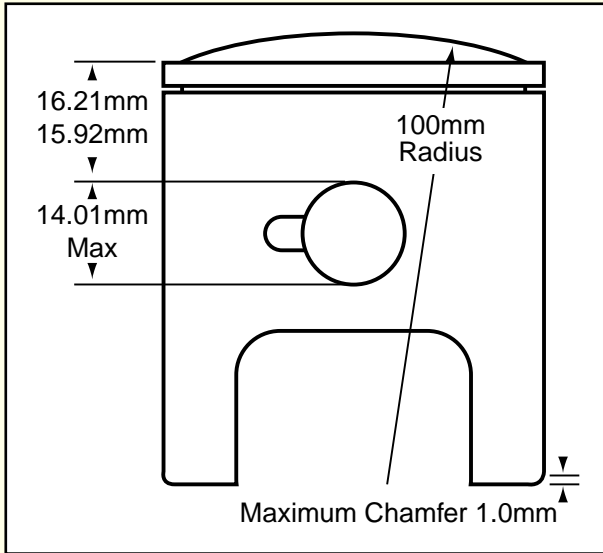

DIAGRAM IS FOR DIMENSIONAL REFERENCE ONLY

31.27 Gudgeon Pin:

No special alloys. Must be standard as per diagram.

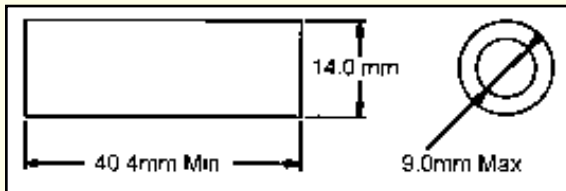

DIAGRAM IS FOR DIMENSIONAL REFERENCE ONLY

31.28 Exhaust, Intake and Transfer Ports:

Cylinder and liner

1. All ports in the liner to be "as machined" condition NO grinding is permitted.
2. All passages must remain in as cast condition; sandblasting, glass beading, peening, etc. are NOT a substitute for "as cast" condition.

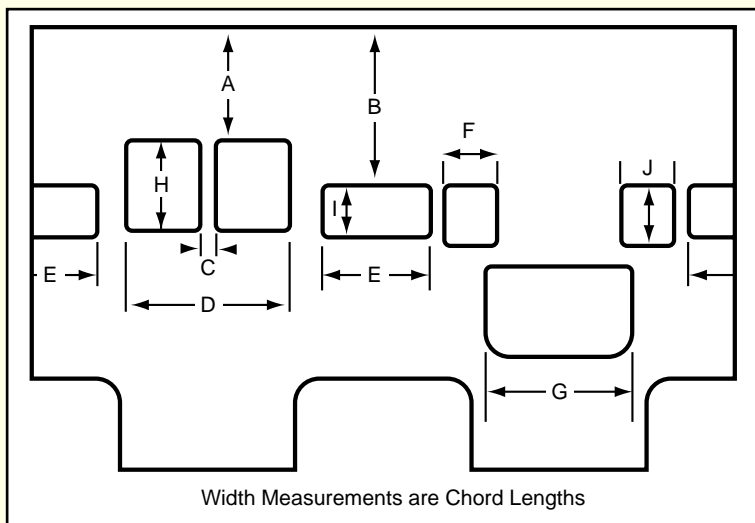

DIAGRAM IS FOR DIMENSIONAL REFERENCE ONLY

CODE	DIMENSION	CODE	DIMENSION
A	26.29 mm min	F	12.95 mm max
B	36.14 mm min	G	34.10 mm max
C	3.70 mm min	H	21.65 mm max
D	39.10 mm max	I	11.80 mm max
E	23.60 mm max	J	13.80 mm max

31.29 Connecting Rod:

- (a) Connecting rod must have either ARC or 213 forged into the side of the rod.
- (b) Minimum/Maximum rod length, centre to centre 99.87mm – 100.13mm.
- (c) Conrod alignment may be either top or bottom.
Bearings and spacers are non-tech items.

31.30 Crankshaft:

Must be of original engine manufacturer.

- (a) Crank Pin to be standard hollow pin 18mm
- (b) Crank Pin length 44.80mm min, 45.00mm max
- (c) Crank Pin bore diameter measurement: 10.25 mm min, 10.45 mm max.
- (d) Crank Shaft outside diameter measurement: 86.60mm min., 87.25mm max.

Note: If the crank assembly is outside the min/max dimensions, then disassemble engine to inspect further. Crankshaft width (measured across shoulder for the main bearings) to be 45.59 mm min.

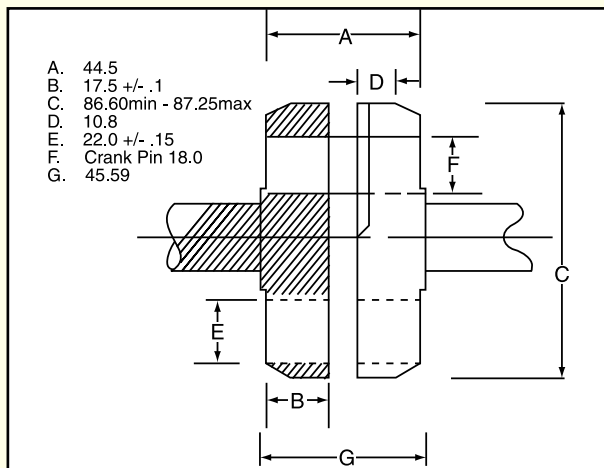

DIAGRAM IS FOR DIMENSIONAL REFERENCE ONLY

31.31 Crankcase:

The crankcase ports will remain as cast. The minimum chordal distance measured with a vernier caliper across the widest section of the transfer ports shall be 97.5mm minimum. (Refer diagram Rule 34.46).

NOTE: Existing crankcases that are narrow may be spaced with a thicker gasket.

THE FOLLOWING SECTION COVERS HYBRID ENGINES WHERE ALTERNATE CONNECTING ROD, CRANKSHAFT AND CRANKCASE MAY BE USED.

31.32 Connecting Rod:

Can be either of the following and must be stock:

- (a) Yamaha or KSI.
- (b) Minimum/Maximum rod length, centre to centre 99.87mm – 100.13mm.
- (c) Conrod alignment may be either top or bottom.

Bearings and spacers are non-tech items.

31.33 Crankshaft:

Legal crankshafts are Yamaha, or KSI

- (a) Outside diameter measurement: 86.60mm min., 87.25mm max.

(b) Crank Pin to be standard hollow pin.

Note: If the crank assembly is outside the min/max dimensions, then disassemble engine to inspect further. Crankshaft width (measured across shoulder for the main bearings) to be 45.50 mm min

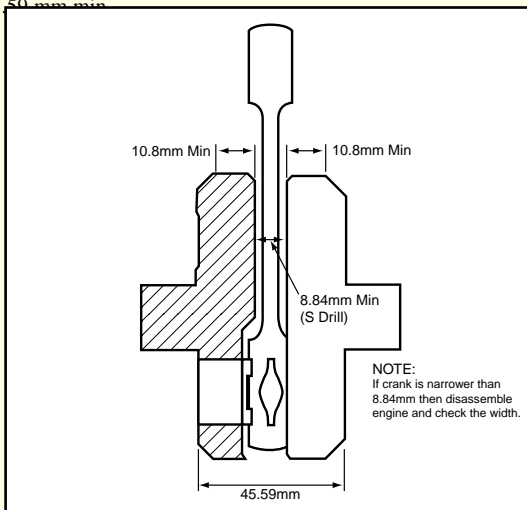
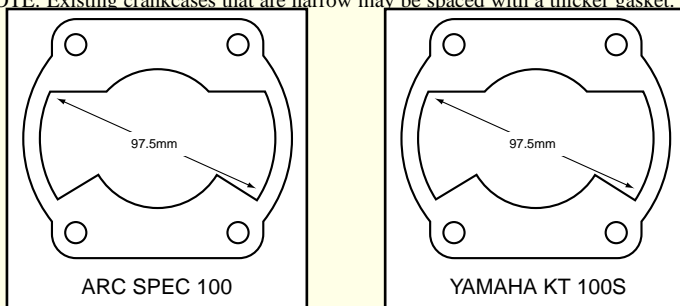

DIAGRAM IS FOR DIMENSIONAL REFERENCE ONLY

31.34 Crankcase:

The crankcase ports will remain as cast. The minimum chordal distance measured with a vernier caliper across the widest section of the transfer ports shall be 97.5mm minimum. (Refer diagram below).

NOTE: Existing crankcases that are narrow may be spaced with a thicker gasket.



DIAGRAMS ARE FOR DIMENSIONAL REFERENCE ONLY

31.35 Engine Measuring Procedure Using Official AKA Gauges:

The AKA Gauges have been designed to make engine measuring quick and easy.

Spacers/gaskets may be used to achieve correct cylinder length/dimension in accordance with this rule and must remain in place for all subsequent measurements.

If an engine fails when measured with these gauges, the competitor may request that the engine be re-measured using the AKA MASTER MEASURING GAUGES (CERTIFIED).

- Step 1.** Insert 10mm ring into head gasket recess (gasket removed).
- Step 2.** Fit 10.5mm Gauge and rotate engine to top dead centre. If piston fails to contact gauge, engine is deemed illegal.
- Step 3.** Insert 5mm diameter piston stop gauge in bottom of inlet port. Rotate engine until piston skirt contacts gauge firmly.
- Step 4.** Insert 26.5mm Gauge into bore above gudgeon pin centre line against cylinder wall. Gauge must not contact 10mm ring when in contact with piston.
- Step 5.** Check exhaust port height.

Note: The following procedure is to check if the removable liner has been removed and the manufactured distance between the top of the exhaust port and the top of the transfer ports has been altered. The dimension between these two port edges is 9.85mm min – 10.10mm max.

- Step 6.** Insert AKAARC Gauge into the cylinder so that it sits on the top of the cylinder liner.
 - Step 7.** With the horizontal locking screw loose, and the gauge head set on Step 8,9, depress the spring loaded gauge shaft and push the gauge across and into the exhaust port and release the pressure on the pin.
 - Step 8.** After ensuring the small diameter section of the gauge ring on the shaft has registered against the top of the exhaust port, tighten the locking screw.
 - Step 9.** Slide the gauge out of the exhaust port and then slide it around against each transfer port. If the larger diameter section of the gauge ring enters a transfer port then the engine is deemed illegal.
 - Step 10.** With the horizontal locking screw loose, and the gauge head set on Step 11,12, depress the spring loaded gauge shaft and push the gauge across and into a transfer port and release the pressure on the pin.
- (All four (4) transfer ports will be equidistant from the top of the liner. All tolerances included.)*
- Step 11.** After ensuring the large diameter section of the gauge ring on the shaft has registered against the top of the transfer port, tighten the locking screw.
 - Step 12.** Slide the gauge out of the transfer port and then slide it around against each exhaust port. If the smaller diameter section of the gauge ring enters an exhaust port then

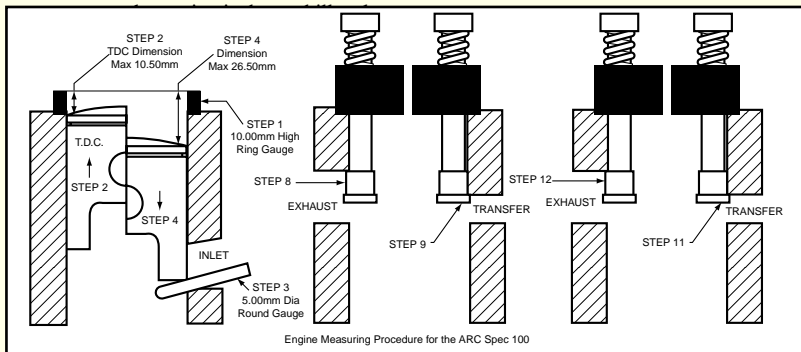

DIAGRAM IS FOR DIMENSIONAL REFERENCE ONLY

CHAPTER 32 - PRD RK100 ENGINE CLASS

32.01 **Engine Eligibility:**

PRD RK100. All parts to be the Original Engine Manufacture (OEM)

32.02 **Tyres**

1. No modifications permitted, tyre treatment is illegal (refer rule 23.03)
2. **Dry Weather Tyres** Maxxis HG3 (1 set + 1 replacement tyre / meeting)
Adjusted AKA Contracted Price: \$208.00 – Maximum Retail Fixed Price
3. **Wet Weather Tyres** Maxxis WT3TKM (1 set + 1 replacement tyre / meeting)
Adjusted AKA contracted price: \$192.00 – Maximum Retail fixed Price

32.03 **Braking:**

Front wheel brakes are not permitted. Refer Rule 25.07(iv).

32.04 **Fuel:**

Refer Rule 25.14. Fuel, as run, to comply to test under Rule 22.01.

32.05 **Weights:**

To be determined on a State by State basis.

32.06 **Cylinder Head:**

A squish area must remain, but combustion chamber shape free.

32.07 **Exhaust Port Height:**

As per cylinder drawing and equal to 176 degree maximum exhaust duration.

Measuring Procedure:

- 1) Use a 50mm stroke dial gauge.
- 2) Select top dead centre and zero gauge.
- 3) Turn engine in direction of rotation.
- 4) Lower Piston 29.0mm.
- 5) The exhaust should be closed when viewed through the exhaust port from outside of the engine.

32.08 **Inlet Port Timing:**

As per cylinder drawing and equal to 165 degree duration.

Measuring Procedure:

- 1) Select top dead centre.
- 2) Place 5mm AKA gauge rod in the inlet port hole.
- 3) Rotate the engine until piston contacts 5mm gauge.
- 4) This measurement should not exceed 19.5mm from TDC.

The method may also be employed using a Vernier Calliper.

Inspection must allow for the distance that the piston ring is below the cylinder liner when using the Vernier Calliper system.

32.09 Exhaust, Inlet and Transfer Ports:

To be controlled by cord measurement as per cylinder drawing. No extra ports allowed.

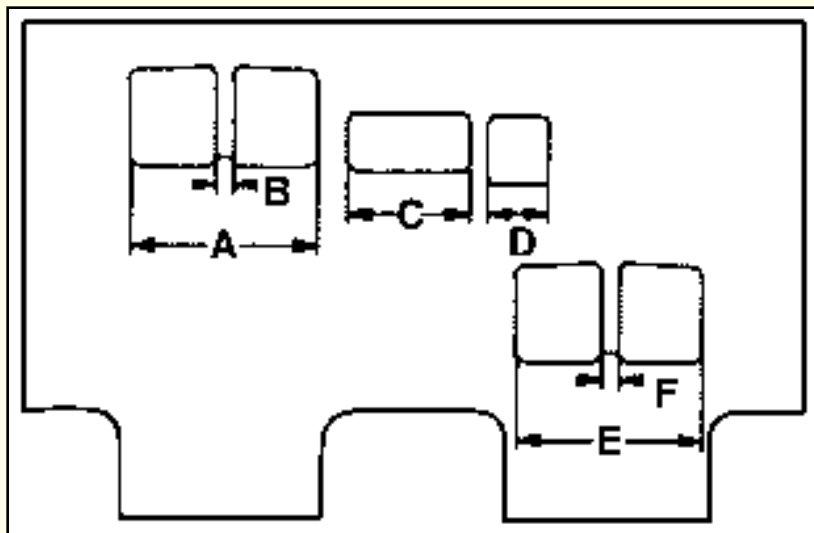

CODE	DIMENSION	CODE	DIMENSION
A	41mm max	D	16mm max
B	3.0mm min	E	41mm max
C	22mm max	F	3.0mm min

DIAGRAM IS FOR DIMENSIONAL REFERENCE ONLY

No Go Gauges for the port measurements are available from your State Secretary.

32.10 Piston:

Original Engine Manufacture

32.11 Conrod:

As supplied by manufacturer. No modifications permitted.

32.12 Crankshaft:

As supplied by manufacturer. No modifications permitted.

32.13 Ignition System:

As supplied by manufacturer. No modifications permitted except repair of hi-tension lead. Both Internal and External Coil / TCI Unit accepted.

32.14 Exhaust Muffler:

The homologated muffler PRD 9037/95 A or PRD 9037/EVO 99A only.

32.15 Carburettor:

Restricted to Walbro WB series only

A=24.4mm B=25.7mm

A=24.0mm B=27.8mm

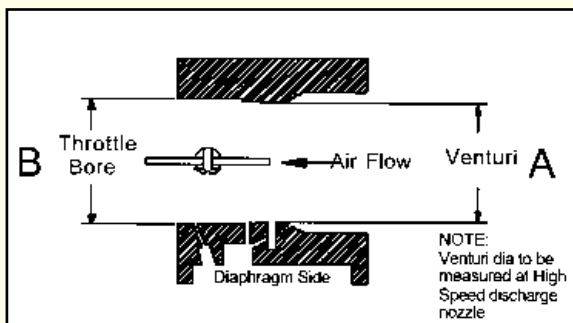

All fuel must pass through the two adjustable jets, no third jet is allowed under any circumstances. The dimension of the fuel passages and air bleed are free.

32.16 Carburettor Spacer Block:

As supplied by the manufacturer but thickness is free.

32.17 Airbox and Carburettor Adaptor: As per R 25.28

32.18 Internal Additions:

No additional material of any kind may be added except in the case of engine repair and shall only restore engine or components to original specification.

32.19 Removal of Material:

Removal of material from inside of engine is free on parts designated as non-tech to specifications found in these regulations.

32.20 External Appearance:

All casting and components must be as supplied and appear as manufactured. Except for minor accident damage which may be repaired (ie. fins).

32.21 Port Finish:

Finish of all ports and passages are free however shape and style must remain as supplied.

32.22 Non-Tech Items:

The following items are considered non-tech items and are free : Piston pin, piston pin circlips, gaskets, crankpin, spacers and washers, seals, drive sprocket, fasteners, exhaust header length, exhaust flex, fin dampeners, spark plug and plug cap, carburettor diaphragms, gaskets and bearings.

32.23 Limitations on drivers:

32.24 Fin Dampeners

To effectively reduce noise all PRD engines must be fitted with fin dampeners to cylinder and head fins.

CHAPTER 33 - RESA CLASS

Preamble

This class has National and State Championship status, however it is not eligible to run at the National Championships (R20.21(i))

The regulations of the ReSa National Championship will be published by the NKC on an annual basis.

33.01 Engine Eligibility:

PCR PV50 and ReSa PV 50 engines only

All engine parts must be as homologated unless specified.

Pistons – PCR black or silver

33.02 Non Technical Items

- ❖ All Bearings
- ❖ Piston Circlips
- ❖ Seals
- ❖ Fastners
- ❖ Fin Dampners
- ❖ Gaskets
- ❖ Piston Pin, Crank Pin
- ❖ Spacers and washers
- ❖ Drive Sprocket
- ❖ Exhaust Flex
- ❖ Spark Plug, Spark Cap and Lead
- ❖ All Port Surfaces

33.03 Ignition - Group 2 FMK ignitions are approved.

33.04 Port Duration:

- (a) Maximum exhaust port duration of 177 (+ or – 2) degrees as per FMK measurement.

Note: If the engine is to compete in Piston Port Class maximum exhaust port duration of 177 degrees is required (all tolerances included).

33.05 Bore Size:

Maximum Bore oversize 50 .5mm

33.06 Carburettor:

- 1 Walbro WB series as per KT 100S:
Venturi - 24.13mm, Throttle Bore - 25.7mm,
- 2 Walbro WB as per FMK Inter A Junior:
Venturi - 24.00mm, Throttle Bore - 27.8mm
- 3 PCR BF24A
Venturi – 24mm, Throttle Bore – 27.7mm

33.07 Exhaust Muffler:

Exhaust muffler must be either CIK192-E-06 (PCR) or CIK 195-E-06 (PCR). Or 278 E/95 PCR or 144 E/92 PCR.

33.08 Chassis & Body Work:

- 1 Any chassis approved for general competition
- 2 Bodywork as per AKA Manual plus front fairing (nose cone) compulsory
- 3 Race Numbers - Black on Yellow background.

33.09 Tyres:

1. No modifications permitted, tyre treatment is illegal (refer rule 23.03)
2. **Dry Weather Tyres:** MG AZ - Red (1 set + 1 replacement tyre / meeting
Adjusted AKA Contracted Price: \$195.00 per set. Maximum retail fixed price.
3. **Wet Weather Tyres:** Maxxis WT3TKM (1 set + 1 replacement tyre / meeting
Adjusted AKA Contracted Price: \$192.00 per set. Maximum retail fixed price.

33.10 Braking:

Front wheel brakes are not permitted. (Refer Rule 25.07)

33.11 Fuel:

Refer Rule 25.14. Fuel, as run, to comply to test under Rule 22.01.

33.12 Weights: Kart and driver as raced.

- (a) ReSa Light - 140 Kg
- (b) ReSa Heavy - 160 Kg

33.13 Limitations on Drivers

To be eligible to compete in this class a competitor must hold a minimum provisional C Grade licence.

34.01 Engine Eligibility:

- For 2001 – Yamaha KT100S, ARC Spec 100A.
- From 1 January 2002 – Yamaha KT100S only.

34.02 Tyres:

1 No modifications permitted, and **Tyre Treatment** is illegal. (Refer Rule 23.03)

2 Dry Tyres:

Vega XSL 1 set plus 1 replacement tyre / meeting. Refer R 19.34.

Adjusted AKA Contracted Price: \$199.00 per set. Maximum Retail Fixed Price.

3 Wet Weather Tyres:

MAXXIS WT3TKM 1 set plus 1 replacement tyre / meeting. Refer R 19.34

Adjusted AKA Contracted Price: \$192.00 per set. Maximum Retail Fixed Price.

34.03 Braking:

Front wheel brakes are not permitted. Refer Rule 25.07 (iv)

34.04 Fuel:

Refer Rule 25.14. Fuel, as run, to comply to test under Rule 22.01

34.05 Weights:

- (a) Clubman Light 135 Kg
- (b) Clubman Heavy – 155 Kg
- (c) Clubman Super Heavy – 175 Kg
- (d) Clubman over 40 (yrs) – 155Kg

Maximum kart weight for Clubman Heavy and Super Heavy Class – 83 kgs.

(Kart as raced and prior to Class weight measuring). (Refer Rule 25.23 (b)).

34.06 Controlled Muffler:

A registered AKA silencer is mandatory for 100cc Clubman as of 1st July 2000. (Refer Rule 25.26).

34.07 Exhaust Pipe Header:

This item is not restricted to the original Manufacturer but must completely conform to the type (style) and dimensional sizes of the original header pipe. Inside diameter must be parallel. Length must be a minimum of 120mm (as per new measuring method). Maximum inside diameter 36mm. Minimum diameter 34mm. Refer diagram. Modifications to fit exhaust gas temperature gauge sensors are permissible.

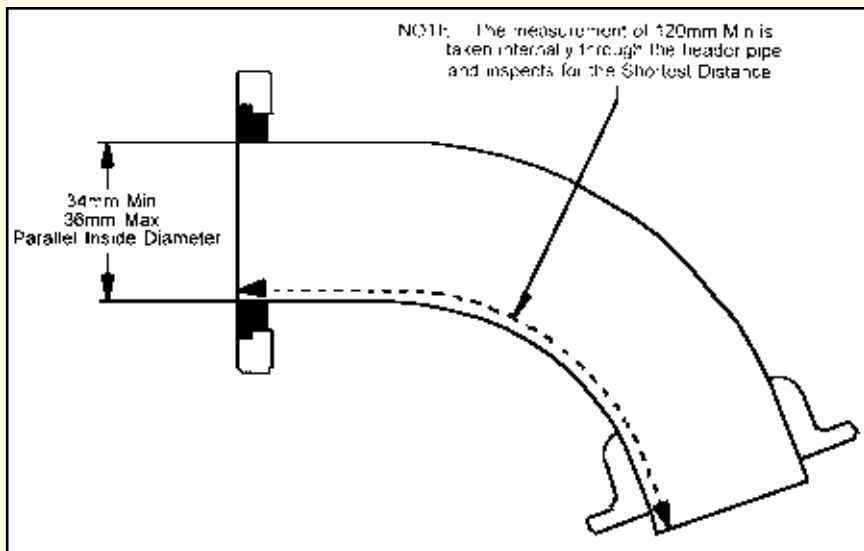

DIAGRAM IS FOR DIMENSIONAL REFERENCE ONLY

PART 1

**This section covers the KT100S series engines
which conforms to the Yamaha Specifications as approved by the A.K.A. Any alterations /
modifications are strictly prohibited except as specifically authorised within these rules.**

34.08 External Modifications:

External modifications, which do not in any way affect a performance gain, are legal.

34.09 Internal Additions:

No additional material may be added except in the case of engine repairs and shall only restore engine or components to original specifications. The cylinder may NOT be repaired in any of the port or passage as cast areas.

- (a) The use of thermal barrier coatings / ceramic coatings on or in the engine / engine components and on or in exhaust components is prohibited.
- (b) The use of anti friction coatings on or in the engine / engine components is prohibited.

34.10 Legal Additions:

Legal additions shall be limited to the following: Chain guard, motor mount, direct drive gear, extension of carburettor jet needles, carburettor return springs, third bearing and adapter, temperature gauge and tachometer.

34.11 Clutch:

A clutch is not permitted in this Class.

34.12 **Non-Tech Items:**

Refer Rule 25.25

34.13 **Displacement:**

The maximum bore and stroke are:

Bore 53.00mm

Stroke 46.13mm

34.14 **Exhaust, Intake and Transfer Ports:** Check the port height and width as per the diagram.

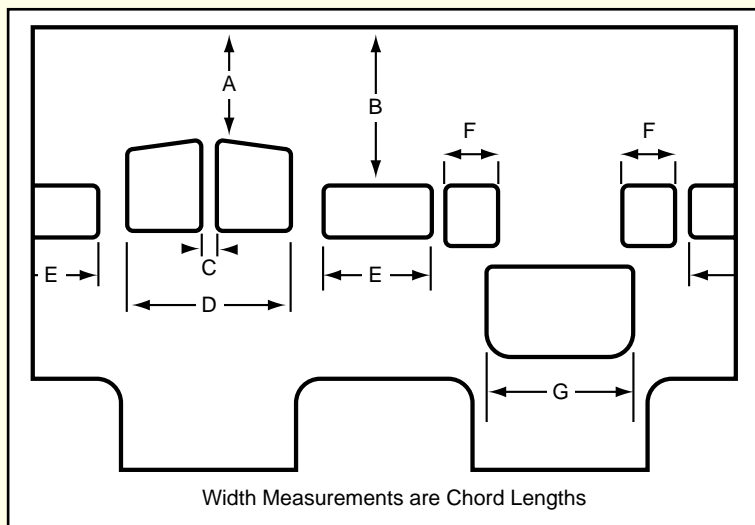

DIAGRAM IS FOR DIMENSIONAL REFERENCE ONLY

CODE	DIMENSION	CODE	DIMENSION
A	26.29 mm min	D	39.60 mm max
B	36.07 mm min	E	26.15 mm max
C	3.40 mm min	F	13.34 mm max
		G	34.80 mm max

34.15 Engine Measuring Procedure for the Yamaha KT100S Engine Using Official AKA Gauges:

The AKA Gauges have been designed to make engine measuring quick and easy.

Spacers/gaskets may be used to achieve correct cylinder length/dimension in accordance with this rule and must remain in place for all subsequent measurements.

If an engine fails when measured with these gauges, the competitor may request that the engine be re-measured using the AKA MASTER MEASURING GAUGES (CERTIFIED).

Step 1. Insert 10mm ring into head gasket recess (gasket removed).

Step 2. Fit 10.5mm Gauge and rotate engine to top dead centre. If piston fails to contact gauge, engine is deemed illegal.

Step 3. Insert 5mm diameter piston stop gauge in bottom of inlet port. Rotate engine until piston skirt contacts gauge firmly.

- Step 4.** Insert 26.5mm Gauge into bore above gudgeon pin centre line against cylinder wall. Gauge must not contact 10mm ring when in contact with piston.
- Step 5.** Check exhaust port height.

Please note: The AKA Gauges can be purchased from your State Secretary.

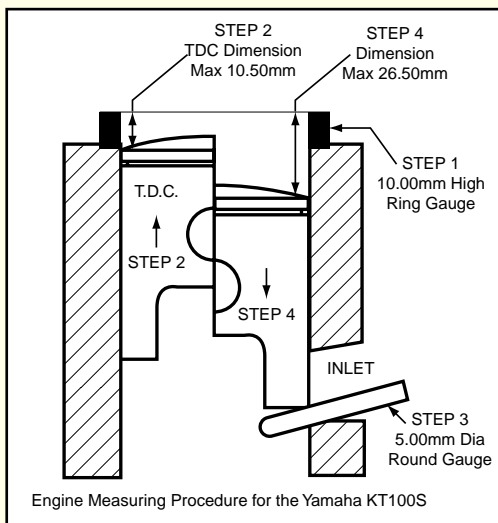

DIAGRAM IS FOR DIMENSIONAL REFERENCE ONLY

34.16 Yamaha KT100S cylinder:

- All ports are to be in "as cast" condition except at the junction of the cast iron sleeve and aluminium jacket. Grinding is permitted to remove casting irregularities at the junction ONLY. No chamfer on port edges is permitted.
This Rule DOES NOT allow grinding or alternations by any method to:
 - change the roof angle;
 - alter port height, width or angle;
 - change the shape or size of the passages from the cylinder base to the port;
 - match the cases to the port passages.
- Sandblasting, glass beading, peening, etc. are NOT a substitute for "as cast" condition.
- Due to manufacturing procedures, it is possible that some engines may have slightly "broken" port edges. When this exists it is uniform on all port edges (tops, bottoms and sides) of all ports in the cylinder. The intersection of the port edges and the cylinder wall must still be within the technical measurements. As the bore size increases the amount of "break" diminishes. If the cylinder bore is 52.45mm or larger, no "broken" edges are allowed.
- Due to manufacturing procedures, some KT-100SD and KT-100SE cylinders have some minor grinding on the transfer divider bridges and some evidence of casting irregularities removed in transfer passages, this includes the transfer area in the crankcase.

34.17 Cylinder Head:

- 1 Must be an original Yamaha casting.
- 2 The welding and re-machining of the combustion area, gasket face and spark plug surface is allowable.
- 3 The combustion chamber style is required to have a squish band and chamber which are visually concentric to the spark plug.
- 4 The combustion chamber volume shall be a minimum of 11cc. (Ref rule 22.03)
- 5 The combustion chamber/squish area shall not protrude beyond the gasket sealing face of the cylinder head.
- 6 The spark plug thread may be repaired and shall retain its original position.

34.18 Head Gasket(s):

Must be retained.

34.19 Piston:

Piston must be approved and stock appearing.

Legal pistons for 2000 are YAMAHA, KSI, KSI MK II, JDP/Vertex and ARC (forged and cast) and Strike.

Bottom of piston should be 90 degrees to sides. It is permissible to notch the piston to allow the removal of circlip. The piston skirt length may be machined, providing it conforms to the current specifications as laid down in these Rules.

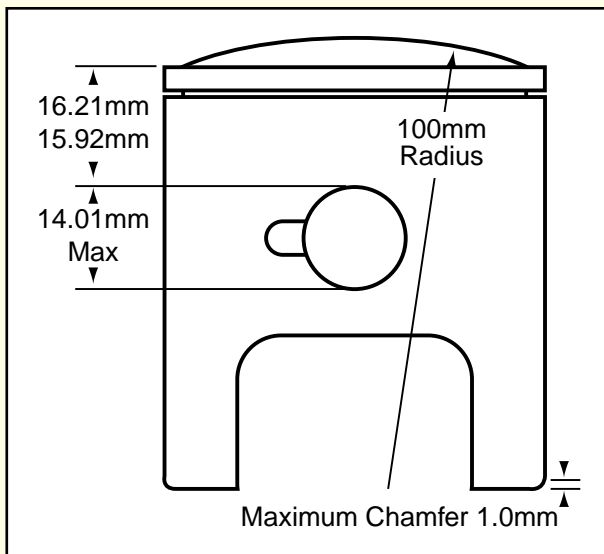

DIAGRAM IS FOR DIMENSIONAL REFERENCE ONLY

34.20 Gudgeon Pin:

No special alloys. Must be standard as per diagram.

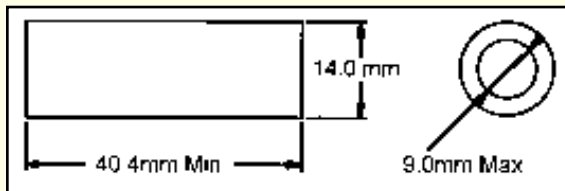

DIAGRAM IS FOR DIMENSIONAL REFERENCE ONLY

34.21 Connecting Rod:

Can be either of the following and must be stock:

- (a) Yamaha, ARC or KSI.
- (b) Minimum/Maximum rod length, centre to centre 99.87mm – 100.13mm.
- (c) Conrod alignment may be either top or bottom.

Bearings and spacers are non-tech items.

34.22 Crankshaft:

Legal crankshafts are Yamaha or KSI

- (a) Outside diameter measurement: 86.60mm min., 87.25mm max.
- (b) Crank Pin to be standard hollow pin.

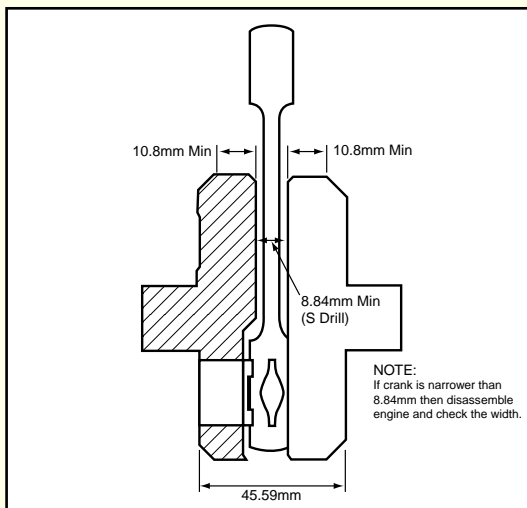

DIAGRAM IS FOR DIMENSIONAL REFERENCE ONLY

34.23 Crankcase:

The crankcase ports will remain as cast. The minimum chordal distance measured with a vernier caliper across the widest section of the transfer ports shall be 97.5mm minimum. (Refer diagram below).

NOTE: Existing crankcases that are narrow may be spaced with a thicker gasket.

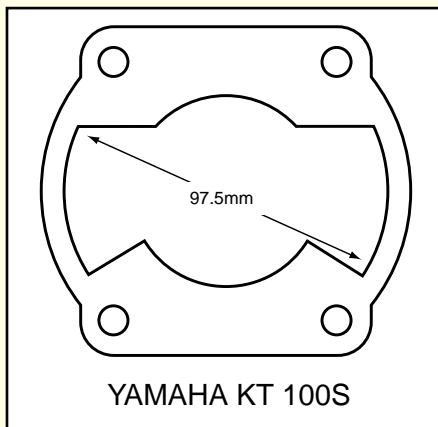

DIAGRAM IS FOR DIMENSIONAL REFERENCE ONLY

34.24 Ignition:

- Ignition must be that supplied by the original engine manufacturer which is approved by the AKA. Any optional unit must be approved and registered with the AKA for this class. The use of the following AKA approved TCI module is permissible:
YAMAHA, VICTA, ATOM, DELTA/WEI SHIEH, PRD
No modifications or repairs to any of the listed AKA approved modules is permitted. The fitting of a PRD ignition coil and a PRD ignition rotor (flywheel) is permissible.
- Ignition timing may be adjusted by the removal of the locating key or part thereof.
- All engines must rotate in a clockwise direction when viewed from the drive side.
- Ignition/rotor cover optional.

34.25 Carburettor:

Must be Walbro WB series conforming to dimensions as per diagram. (Note - WB 24 is not eligible)

- It is permissible to machine the Walbro carburettor body to
 - conform to dimension E
 - conform to dimension C
 - accept an O ring for the low speed jet.
- A threaded butterfly screw must be retained.
- Pump diaphragms: Either Teflon or rubber types are legal.
- It is permissible to repair the inlet seat and throttle shaft bore in the Walbro carburettor.
- It is permissible to enlarge only existing fuel / air holes, but they may not be deleted or relocated.
- All air must pass through the carburettor venturi.
- Measurement code:

- A As cast MAX Venturi diameter 24.13mm
- B As cast (area will extend from the front of the carburettor to the progression discharge jet which must have all or portion of this jet in the cast area.)
- C MAX downstream diameter 25.7mm
- D Butterfly shaft must be located at the bore centre.
- E MIN carburettor body length of 37.5mm.

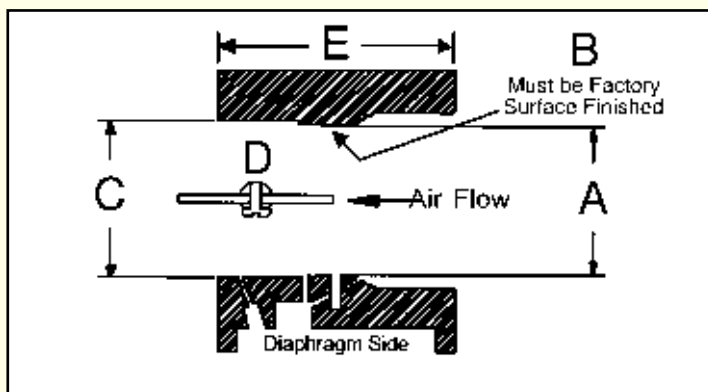

DIAGRAM IS FOR DIMENSIONAL REFERENCE ONLY

34.26 Pressurised Fuel System:

Fuel pump or pressurised fuel systems are forbidden. Squeeze type pump between fuel tank and carburettor is permitted.

34.27 Inlet Tract Length:

65mm minimum. The inlet tract is to be measured from aluminium carburettor adaptor outer face to skirt of piston.

34.28 Phenolic Spacer:

Hole size 26.42mm max.

34.29 Aluminium Carburettor Mount Plate:

Hole size 26.29mm max.

34.30 Fin Dampeners:

To effectively reduce noise, it is compulsory that the Yamaha KT100S Series Engine be fitted with:

- (a) A minimum of four rows of fin dampeners on the cylinder. Fin dampeners must make contact with all fins.
- (b) Two rows of fin dampeners are to be fitted to the cylinder head. Fin dampeners must make contact with all fins.

**This section covers the ARC SPEC 100 series engine
which conforms to the Specifications as approved by the A.K.A. Any alterations /
modifications are strictly prohibited except as specifically authorised within these rules.**

The ARC Spec 100 air cooled must have “Mod 2” cast into the web between the two top fins of the cylinder barrel in the position at the front of the engine on the ignition side.

34.31 External Modifications:

External modifications which do not in any way affect a performance gain are legal.

34.32 Internal Additions:

No additional material may be added except in the case of engine repairs and shall only restore engine or components to original specifications. The cylinder may NOT be repaired in any of the port or passage as cast or machined areas.

- (a) The use of thermal barrier coatings / ceramic coatings on or in the engine / engine components and on or in exhaust components is prohibited.
- (b) The use of anti friction coatings on or in the engine/engine components is prohibited.

34.33 Legal Additions:

Legal additions shall be limited to the following: Chain guard, motor mount, direct drive gear, extension of carburettor jet needles, carburettor return springs, third bearing and adaptor, temperature gauge and tachometer.

34.34 Clutch:

A clutch is not permitted in this Class.

34.35 Non-Tech Items:

Refer Rule 25.25

34.36 Displacement:

The maximum bore and stroke are:

Bore 53.00mm Stroke 46.13mm

34.37 Exhaust, Intake and Transfer Ports:

Cylinder and liner

1. All ports in the liner to be “as machined” condition NO grinding is permitted.
2. All passages must remain in as cast condition; sandblasting, glass beading, peening, etc. are NOT a substitute for “as cast” condition.

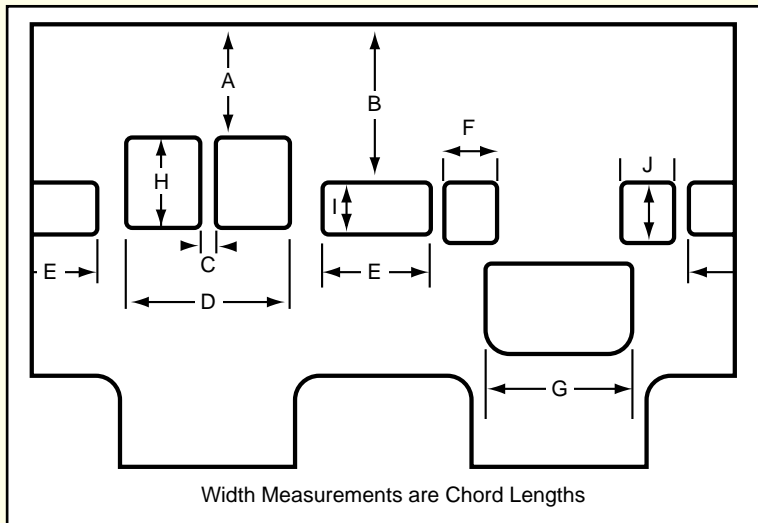

DIAGRAM IS FOR DIMENSIONAL REFERENCE ONLY

CODE	DIMENSION	CODE	DIMENSION
A	26.29 mm min	F	12.95 mm max
B	36.14 mm min	G	34.10 mm max
C	3.70 mm min	H	21.65 mm max
D	39.10 mm max	I	11.80 mm max
E	23.60 mm max	J	13.80 mm max

34.38 Engine Measuring Procedure Using Official AKA Gauges:

The AKA Gauges have been designed to make engine measuring quick and easy.

Spacers/gaskets may be used to achieve correct cylinder length/dimension in accordance with this rule and must remain in place for all subsequent measurements.

If an engine fails when measured with these gauges, the competitor may request that the engine be re-measured using the AKA MASTER MEASURING GAUGES (CERTIFIED).

Step 1. Insert 10mm ring into head gasket recess (gasket removed).

Step 2. Fit 10.5mm Gauge and rotate engine to top dead centre. If piston fails to contact gauge, engine is deemed illegal.

Step 3. Insert 5mm diameter piston stop gauge in bottom of inlet port. Rotate engine until piston skirt contacts gauge firmly.

Step 4. Insert 26.5mm Gauge into bore above gudgeon pin centre line against cylinder wall. Gauge must not contact 10mm ring when in contact with piston.

Step 5. Top exhaust to top transfer 9.85min - 10.10 max.

Note: The following procedure is to check if the removable liner has been removed and the manufactured distance between the top of the exhaust port and the top of the transfer ports has been altered. The dimension between these two port edges is 9.90mm min – 10.15mm max.

- Step 6.** Insert AKA ARC Gauge into the cylinder so that it sits on the top of the cylinder liner.
- Step 7.** With the horizontal locking screw loose, and the gauge head set on Step 8,9, depress the spring loaded gauge shaft and push the gauge across and into the exhaust port and release the pressure on the pin.
- Step 8.** After ensuring the small diameter section of the gauge ring on the shaft has registered against the top of the exhaust port, tighten the locking screw.
- Step 9.** Slide the gauge out of the exhaust port and then slide it around against each transfer port. If the larger diameter section of the gauge ring enters a transfer port then the engine is deemed illegal.
- Step 10** With the horizontal locking screw loose, and the gauge head set on Step 11,12, depress the spring loaded gauge shaft and push the gauge across and into a transfer port and release the pressure on the pin.
- (All four (4) transfer ports will be equidistant from the top of the liner. All tolerances included.)*
- Step 11** After ensuring the large diameter section of the gauge ring on the shaft has registered against the top of the transfer port, tighten the locking screw.
- Step 12** Slide the gauge out of the transfer port and then slide it around against each exhaust port. If the smaller diameter section of the gauge ring enters an exhaust port then the engine is deemed illegal.

Please Note: The AKA Gauges can be purchased from your State Secretary.

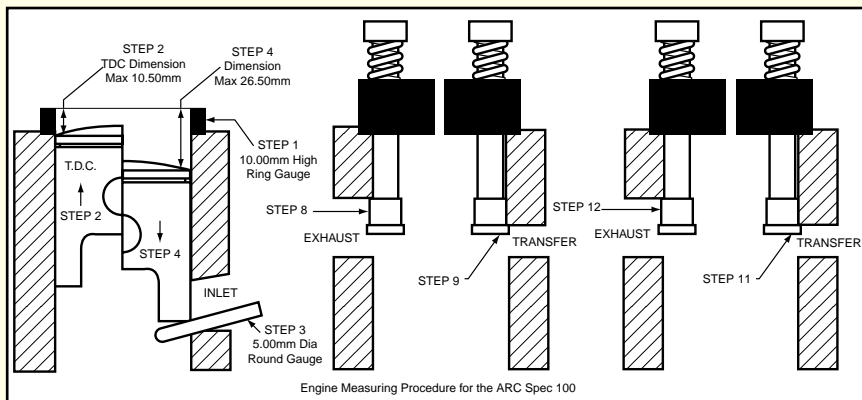

DIAGRAM IS FOR DIMENSIONAL REFERENCE ONLY

34.40 Cylinder Head:

- 1 Must be an original ARC casting.
- 2 The welding and re-machining of the combustion area, gasket face and spark plug surface is allowable.
- 3 The combustion chamber style is required to have a squish band and chamber which are visually concentric to the spark plug.
- 4 The combustion chamber volume shall be a minimum of 11cc. (Ref rule 22.03)
- 5 The combustion chamber/squish area shall not protrude beyond the gasket sealing face of the cylinder head.
- 6 The spark plug thread may be repaired and shall retain its original position.

34.41 **Head Gasket/s:**
Must be retained.

34.42 **Piston:**

1. Piston must be AKA approved ARC (forged or cast) and stock in appearance.
2. Approved aftermarket pistons for 2000 include YAMAHA, KSI, KSI MK II, JDP/Vertex and Strike.
3. Bottom of piston should be 90 degrees to sides. It is permissible to notch the piston to allow the removal of circlip. The piston skirt length may be machined, providing it conforms to the current specifications as laid down in these rules.

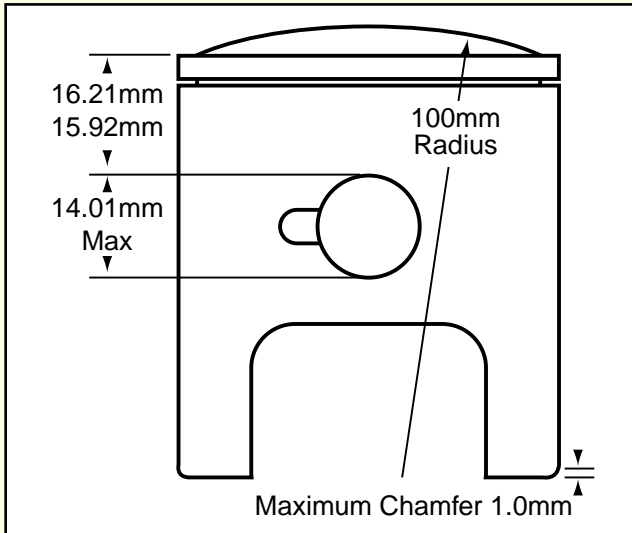

DIAGRAM IS FOR DIMENSIONAL REFERENCE ONLY

34.43 **Gudgeon Pin:**
No special alloys. Must be standard as per diagram.

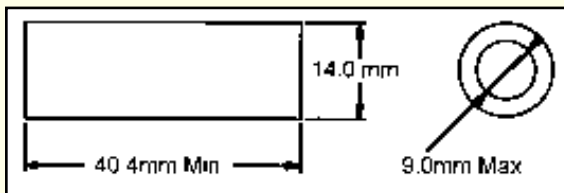

DIAGRAM IS FOR DIMENSIONAL REFERENCE ONLY

34.44 **Connecting Rod:**

- (a) Connecting rod must have either ARC or 213 forged into the side of the rod.
- (b) Minimum/Maximum rod length, centre to centre 99.87mm – 100.13mm.

- (c) Conrod alignment may be either top or bottom.
Bearings and spacers are non-tech items.

34.45 **Crankshaft:**

Must be of original engine manufacturer.

- (a) Crank Pin to be standard hollow pin 18mm
(b) Crank Pin length 44.80mm min, 45.00mm max
(c) Crank Pin bore diameter measurement : 10.25 min -10.45 max
(d) Crank Shaft outside diameter measurement: 86.60mm min., 87.25mm max.

Note: If the crank assembly is outside the min/max dimensions, then disassemble engine to inspect further. Crankshaft width (measured across shoulder for the main bearings) to be 45.59 mm min.

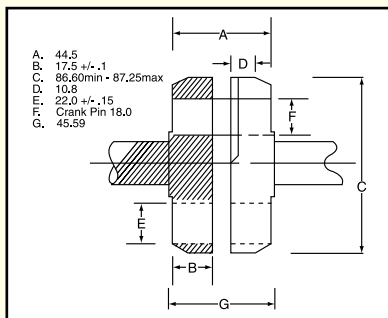

DIAGRAM IS FOR DIMENSIONAL REFERENCE ONLY

34.46 **Crankcase:**

The crankcase ports will remain as cast. The minimum chordal distance measured with a vernier caliper across the widest section of the transfer ports shall be 97.5mm minimum. (Refer diagram below).

NOTE: Existing crankcases that are narrow may be spaced with a thicker gasket.

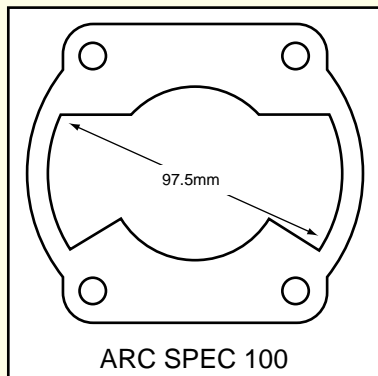

DIAGRAM IS FOR DIMENSIONAL REFERENCE ONLY

34.47 **Ignition:**

- a) Ignition must be that supplied by the original engine manufacturer which is approved by the AKA. Any optional unit must be approved and registered with the AKA for this class. The use of the following AKA approved TCI module is permissible:
YAMAHA, VICTA, ATOM, DELTA/WEI SHIEH, PRD
No modifications or repairs to any of the listed AKA approved modules is permitted. The fitting of a PRD ignition coil and a PRD ignition rotor (flywheel) is permissible.
- b) Ignition timing may be adjusted by the removal of the locating key or part thereof and/or by the ignition plate.
- c) All engines must rotate in a clockwise direction when viewed from the drive side.
- d) Ignition/rotor cover optional.

34.48 **Carburettor:**

Must be Walbro WB series conforming to dimensions as per diagram. (Note - WB 24 is not acceptable)

- (a) It is permissible to machine the Walbro carburettor body to accept an O ring for the low speed jet.
- (b) A threaded butterfly screw must be retained.
- (c) Pump diaphragms: Either Teflon or rubber types are legal.
- (d) It is permissible to repair the inlet seat and throttle shaft in the Walbro carburettor.
- (e) It is permissible to enlarge only existing fuel / air holes, but they may not be deleted or relocated.
- (f) All air must pass through the carburettor venturi.
- (g) Measurement code:
 - A As cast MAX Venturi diameter 24.13mm
 - B As cast (area will extend from the front of the carburettor to the progression discharge jet which must have all or portion of this jet in the cast area.)
 - C MAX downstream diameter 25.7mm
 - D Butterfly shaft must be located at the bore centre.
 - E MIN carburettor body length of 37.5mm.

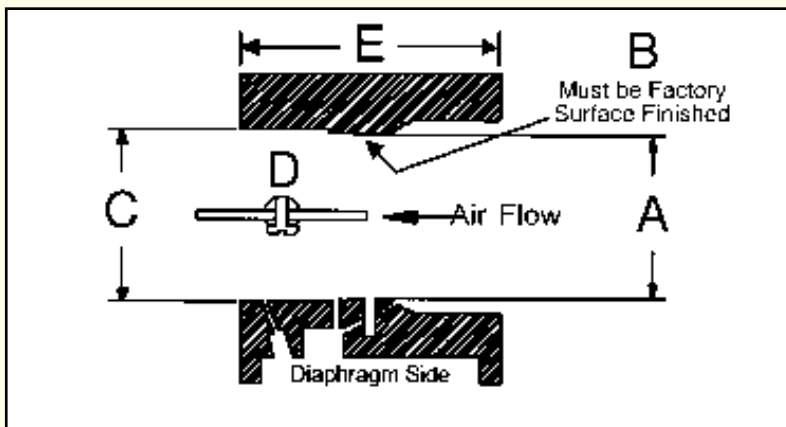

DIAGRAM IS FOR DIMENSIONAL REFERENCE ONLY

- 34.49 **Pressurised Fuel System:**
Fuel pump or pressurised fuel systems are forbidden. Squeeze type pump between fuel tank and carburettor is permitted.
- 34.50 **Inlet Tract Length:**
69mm minimum. The inlet tract is to be measured from aluminium carburettor adaptor outer face to skirt of piston.
- 34.51 **Insulating Spacer:**
Hole size 26.42mm max.
- 34.52 **Aluminium Carburettor Mount Plate:**
Hole size 26.29mm max
- 34.53 **Fin Dampeners:**
To effectively reduce noise all engines must be are fitted with fin dampeners to cylinder and head fins.

CHAPTER 35 - ATLAS ENGINE CLASS

35.01 Engine Eligibility:

Atlas 100K

All parts to be Original Engine Manufacture (OEM).

35.02 Tyres

1. No modifications permitted, tyre treatment is illegal (refer rule 23.03)
2. **Dry Weather Tyres:** Vega XSL (1 set + 1 replacement tyre / meeting)
Adjusted AKA Contracted Price: \$199.00 per set. Maximum Retail Fixed Price
3. **Wet Weather Tyres:** Maxxis WT3TKM (1 set + 1 replacement tyre / meeting)
Adjusted AKA Contracted Price: \$192.00 per set. Maximum Retail Fixed Price.

35.03 Braking:

Front wheel brakes are not permitted. (Refer Rule 25.07)

35.04 Fuel:

Refer Rule 25.14. Fuel, as run, to comply to test under Rule 22.01.

35.05 Weights:

To be determined on a State by State basis.

35.06 Crankcases and Crankshaft:

- 1 Crankcases must be as cast
- 2 Crankshaft as supplied by OEM, no modifications permitted.

35.07 Reed Block:

Neoprene coating must remain on internal area of reed block.

35.08 Reed Petal:

Reed petal thickness minimum is 0.44mm.

35.09 Port Sizes:

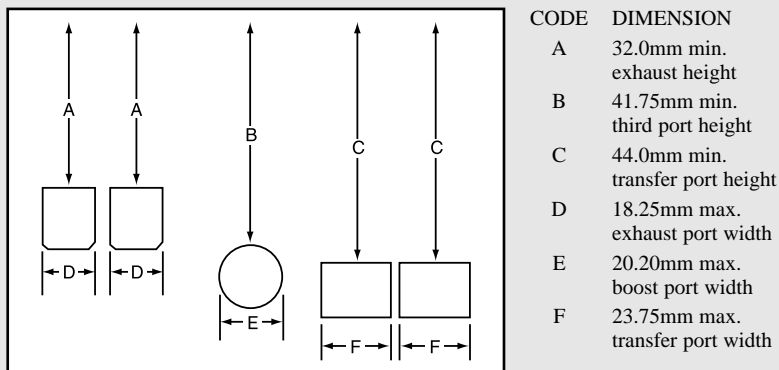

SCHEMATIC DIAGRAM ATLAS 100K LINER

DIAGRAM IS FOR DIMENSIONAL REFERENCE ONLY

- 35.10 **No Go Gauges:**
No Go Gauge will be of port height and width.
- 35.11 **Inlet Tract:**
Min. length to be 45mm measured at the base of the reed valve recess into the crankshaft face, a vernier caliper to be used.
- 35.12 **Exhaust Muffler:**
Refer Rule 25.26 for technical specification.
- 35.13 **Cylinder Head:**
Displacement 11.0 cc, a squish area must remain, the combustion chamber is shape free.
- 35.14 **Piston:**
As supplied by Atlas, no coating of any description is allowed.
(a) Piston Height
The maximum height between the top of the piston to top of the cylinder is 1.00 mm.
- 35.15 **Conrod:**
PRD Conrod as supplied by Atlas. No modifications permitted.
- 35.16 **Ignition System:**
As supplied by manufacturer. No modifications permitted except to repair high tension lead. The only permissible adjustment is by removal of part or all of the ignition key.
- 35.17 **Carburettor:**
Reed carburettor to be Tillotson HL Series - 25.40 mm throat, 22.00 mm Venturi (two jet type)
(1) Maximum two adjustable jets permitted.
(2) No fixed jets permitted.
(3) All fuel to the engine must pass through the high and low fuel metering jets.
- 35.18 **Airbox Adaptor:**
As per Rule 25 29
- 35.19 **Internal Additions:**
No internal additions of any kind except in the case of engine repair to the matching of transfer passage ports.
- 35.20 **Removal of Material:**
Material removal from inside engine is free on parts designed as non-tech, listed later in these specifications.
- 35.21 **External Appearance:**
All castings and components must be as supplied by the manufacturer.
- 35.22 **Port Finish:**
Finish to all ports and passages is free, however size, shape and style must remain as manufactured.

35.23 **Non Tech Items:**

These items are non tech and thus are free - piston pin and piston pin circlips, crankpin and spacers and washers, gaskets, bearings and seals, drive sprocket and fasteners, exhaust header length and exhaust flex, spark plug and plug cap.

Atlas Engine and Pump Company will supply sample cylinder liner for gauge measurement and a master set of No Go Gauges for each State Technical Adviser and the National Secretary.

35.24 **Cylinder Measuring Procedure**

Exhaust Ports

Width. The engine is deemed to be illegal if the 18.25mm gauge enters the port when the gauge is parallel to the machined axis of the port.

Height. The engine is deemed to be illegal when the 32mm gauge fully enters the port and sits flat onto the cylinder bore face.

Spacers/gaskets may be used to achieve correct cylinder length/dimension in accordance with this rule and must remain in place for all subsequent measurements.

Transfer Ports

Width. The engine is deemed to be illegal if the 19mm gauge, when held against the side of the two main transfer ports enters either port.

Height. The engine is deemed to be illegal when the 44mm gauge fully enters the port and sits flat on to the cylinder bore face.

Third Transfer

Width. The engine is deemed to be illegal when the 20.2mm gauge fully enters the port.

Height. The engine is deemed to be illegal if the 41.75mm gauge overhangs the port edge when viewed through the exhaust port.